

Kobra Formen GmbH, 08485 Lengenfeld, Germany

International Architectural Projects – Wausau Tile Inc.

■ Holger Eckelt and Stefanie Schaarschmidt, Kobra Formen GmbH, Germany

The Miami Worldcenter – the second largest private construction project in the USA – is currently built in Miami, Florida. Located between South Beach and Miami Financial Districts, the nearly 30-acre site has been under construction since 2017 and is slated for completion in 2022. In Houston, Texas, several urban modernization and expansion projects are continuously taking place, from the impressively large Convention Center to Post Oak Boulevard to Bagby Street – across the entire city center, so to speak.

Wisconsin-based Wausau Tile Inc. is involved in all of these projects with an experienced team of engineers and project managers, working with local architects and designers to create all of the exterior finishes. Architectural paver and slab systems, as well as outdoor furniture and precast concrete elements, individually manufactured for the respective projects are produced in Wausau Tile's manufacturing facilities in Wisconsin and transported thousands of miles across the United States. By focusing on the project business, Wausau Tile holds a special position in the industry founded on a world-class distribution network combined with state-of-the-art production methods.

Wausau Tile was founded in 1953 by Edward Creske with a clear corporate philosophy of commitment, expertise and innovation that still aptly describes Wausau Tile to this day: Quality and service being the basis for sustainable and long-lasting customer relationships.

In the company's nearly 70-year history, Wausau Tile's product portfolio is continuously expanding. The company opened a new plant for paver production in 2016, which, owing to its production parameters, makes it possible to achieve individual design options in terms of format, color and formulations. All concrete block products are manufactured 100% in Kobra molds using the latest state-of-the-art technologies. A wide range of variations are possible. After selecting the type of stone – Wausau Tile has a standard product range of pavers of over 70 sizes and formats – surfaces and embossments can be chosen in conjunction with the desired coloration. During the color matching process, aggregate and colors are se-

lected in close coordination with the architects and designers in charge of the project so that, for example, color gradients can be individually designed. The concrete block mix design is coordinated with the respective product and satisfy all industry-specific quality criteria.¹

Miami Worldcenter – Master planning for diverse urban land use

Vision, organization and development

The vision of the Miami Worldcenter as an urban nucleus in the heart of one of the world's most vibrant metropolises has existed for several decades. In fact, the project's development phase began back in the early 2000s, and construction finally began in 2017.

The project is led by Miami Worldcenter Associates, a company that specializes in the further development and restructuring of dynamic, densely populated communities in North America and expands underutilized urban neighborhoods and landscapes with strategic investments.²

The ten-block mixed-use site is situated in the heart of the city, housing arts and cultural centers, dining and hospitality, along with residential and commercial properties as well as select retail and entertainment venues.

Nearby attractions include the Perez Art Museum, the Frost Museum of Science and the Arsht Center for the Performing Arts. The Port of Miami, Dade College, Bayside Marketplace and the new federal courthouse are also within walking distance.

Kimley-Horn, one of the nation's leading planning, engineering and design consulting firms, is responsible for the design of all exterior facilities. With its close to 3,500 employees and more than 80 offices across the United States, the company provides extensive services in a wide range of disciplines and looks back on years of experience in the field of public infrastructure projects.³

KOBRA

30 JAHRE
www.kobragroup.com



**30 YEARS
KOBRA
FORMEN GMBH**

MILESTONES IN MOLD TECHNOLOGY

**TOOLS. DRIVEN BY
KNOWLEDGE.**

**CARE. POWERED BY
EXPERIENCE.**

WWW.KOBRAGROUP.COM

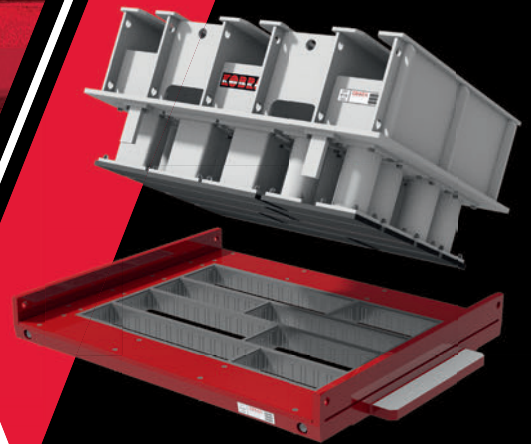

The KOBRA modular concept – the construction method for repairs through cost-efficient replacement of wear parts. Leverage the production costs per square metre.

Moduline™ technology – one frame for different applications. A milestone in mould technology that is used thousands of times worldwide.

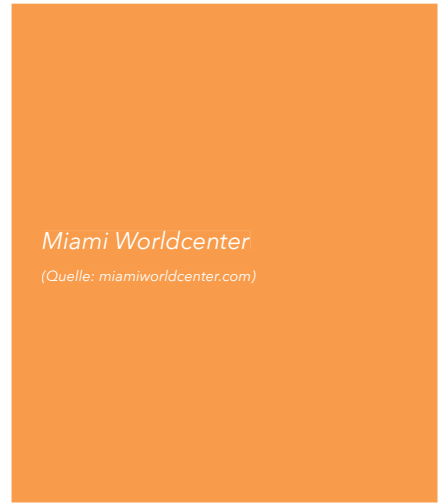

Miami Worldcenter

(Quelle: miamiworldcenter.com)



The creation process of the Miami Worldcenter is being implemented together with the real estate project management and consulting company Square Edge, which has taken over the overall management of the project.⁴

The interaction between project management, architects, designers and the producers of the materials required for the individual construction phases is a challenging logistical and organizational feat that is reflected in the project's master plan. For this reason, the overall construction phase of the Miami Worldcenter is divided into several sectors.

As connecting element, the outdoor area is designed as a lively, walkable pedestrian zone between the individual sections. Unlike the otherwise customary colorful designs in Miami, it is consistently kept in the colors black and white. All buildings also follow this color scheme to draw attention to the numerous cultural venues and shopping areas. Despite the different designs used in the building construction, the entire complex has a very homogeneous and neutral appearance. Unique works by international artists such as the German painter Franz Ackermann, who decorates the east and south facades of one of the numerous buildings with a large-scale mural, brighten up the Miami Worldcenter.

In addition to its art, which is clearly recognizable to pedestrians as well as from afar, other elements are integrated

throughout the area that serve as reference points, such as the legendary Pan Am Globe, which was built in the 1930s in the airline's eponymous terminal, now Miami City Hall. Once its restoration is complete, it will be located at the center of the Miami Worldcenter. According to Square Edge, the purpose of displaying international artworks is to connect the world in the Miami Worldcenter district, which also serve as nodes.

**Pedestrian areas and zones as visual nexuses:
13 million square feet of Wausau paving**

Pedestrian areas and zones, which will be entirely designed using Wausau Tile's paver system, provides yet another visual link between each sector. Several workshops were conducted in close coordination with Kimley-Horn and Square Edge to select various rectangular formats that will be manufactured on concrete block machines as well as hermetic presses. A total of 13 million square feet is slated for the construction project.

The planners and architects chose Wausau Tile because the company has extensive experience in the project business, information and plans were available quickly and the product quality is outstanding. This is consistent with the corporate philosophy of Wausau Tile's founder (see above), which has been successfully continued by the highly committed team to this day.



Laying Wausau pavers

In the development process, various formats and potential installations were first tested. This enabled the architects and project managers involved to see for themselves the modern manufacturing processes at Wausau Tile's headquarters and to define the product characteristics for the project together with their engineers.

For example, the mix design was specially adapted to the particular requirements of the project. In parallel, defining the colors and coordinating the individual color schemes of the stones involved took a great deal of time.



PRODUCTION BOARDS
FOR PAVING STONES AND OTHER CONCRETE ELEMENTS

THE OFFER INCLUDES:

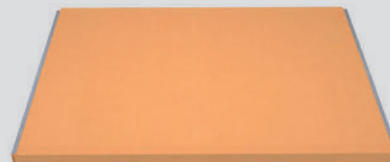

- boards with polyurethane coating



- pine wood boards

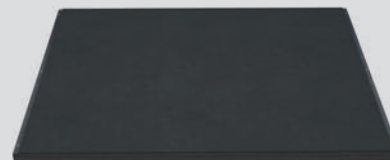

- plywood boards

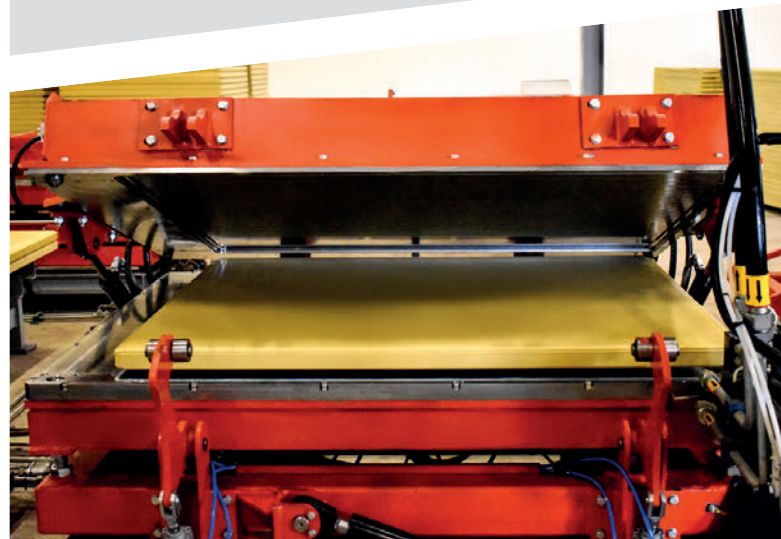

LET'S STAY IN TOUCH!

DOMESTIC SALES

Mob. (+48) 535 073 799

aszczepanowska@polblat.pl

INTERNATIONAL SALES

export.en@polblat.pl

export.ru@polblat.pl



Laying Wausau pavers

As previously mentioned, it was decided to use black and white concrete block systems interspersed with natural stone-look paving to give the companies located in the Miami Worldcenter visual space to design their own areas and to enhance the effect of art and sculptures in the public space.

The paving consists of slender rectangular stones in 24x12 inch and 24x8 inch sizes, manufactured in Kobra molds and combined in the installation with a 12x6 inch concrete block, produced on Wausau Tile's hermetic press.

The installation patterns differ depending on the area within the Miami Worldcenter. Pedestrian walkways, which serve as a link between the individual sectors, are characterized by straight stone laying. In areas where outdoor furniture is installed to invite people to linger, the installation is more varied, but still keeps with the linear look of the overall project.

Finally, in the installation process, the pavers were cut from Kobra shapes while already installed to fit the 12x6 inch stone in a straight line - a unique feature due to the installation pattern chosen. Furthermore, no drainage channels or electrical distribution boxes are visible as they are located beneath the paving, so as not to disrupt the overall appearance.

Special requirements for Kobra concrete block molds

Such a large-scale project also places special demands on the molds needed to produce the concrete blocks. This applies to both the technology and features of the mold itself, as well as the projected wear part replacement.

All Kobra molds used for the Miami Worldcenter project employ Boltline 3™ technology, as their design ensures exact angularity in the cavities. This is essential for the mass of stones to be produced and the laying pattern chosen for the project because the smallest tolerances in surface diagonals and straightness can be adjusted. The entire mold is modular. The insert is made of individual walls with bolted cover plates. To achieve a high cycle rate, the molds are carbonized in Kobra's in-house hardening furnaces and have a hardness grade of at least 68 HRC.

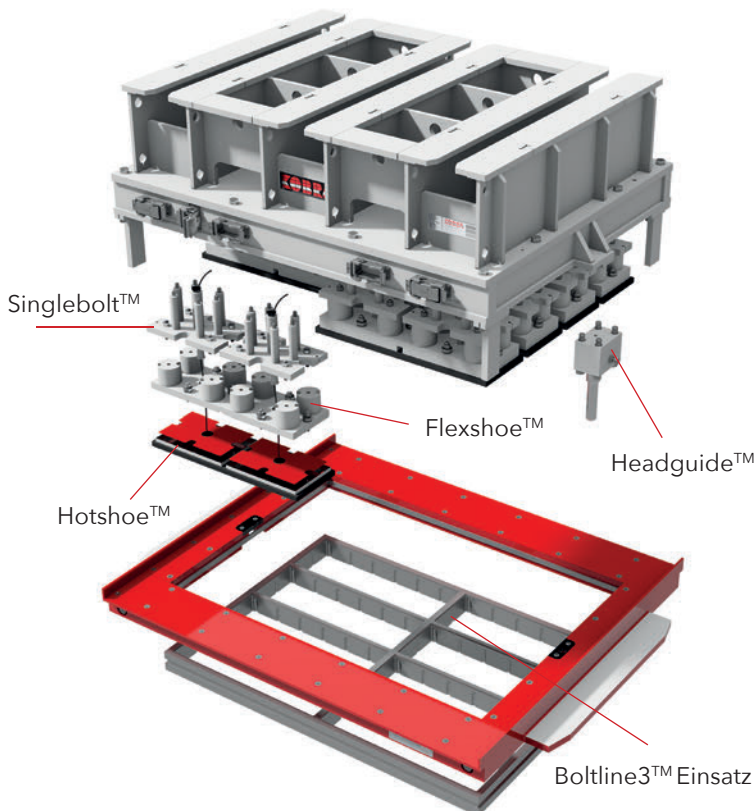

Boltline3™ paver shape from Kobra

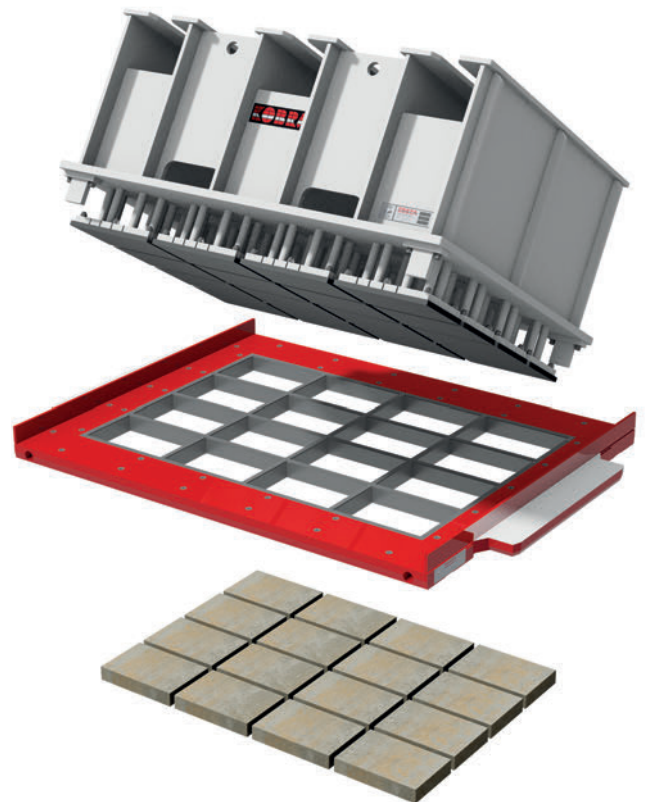

Boltline3™ - Paver mold

The tamper heads are equipped with the Hotshoe™ system, which prevents the shoes from sticking to the concrete and supports the structuring of the stone surface. In combination with Flexshoe™, even better compaction results on the stone can be achieved, as the controlled oscillating shoes provide an additional damping effect and thus an overall improved surface finish.

The molds used for the project are also equipped with the Headguide™ forced centering system. This ensures precision plunging of the tamper head into the mold bottom and also has the effect that the mold is constantly guided in the machine, thus preventing the shoes from hitting the insert walls.

Thirteen million square feet poses special challenges not only in terms of mold technology, but also in terms of the maintenance concept. Using several identical molds makes sense from a manufacturing point of view, but it is not the only strategy when it comes to economical mold management. And this is why Wausau Tile makes use of the benefits that the Kobra modular system offers and replaces wear parts on the mold at regular intervals in order to achieve higher cycle rates overall.

Bagby Street - Sustainable road construction with Greenroads Foundation certification

Combining current demographics and modern transportation planning

For the Bagby Street construction as part of the urban modernization and expansion of Houston's urban core, Wausau Tile partnered with SWA Group, an international landscape architecture and planning company with offices in the U.S. from San Francisco to Houston to New York, and, given its numerous projects in Asia, with studios in the United Arab Emirates and Shanghai.⁵

Bagby Street is the first of currently four construction projects in Houston and the first in the state of Texas to feature a new sustainable streets concept certified by the Greenroads Foundation. The foundation, which evolved from research conducted by the University of Washington and its partners, has developed a system for evaluating sustainable design and construction practices and awards points that can be used to certify projects. This is essentially a collection of 48 sustainability best practices for use in street construction.⁶



FEATURES

- ✓ High productivity
- ✓ Versatile
- ✓ Infinite variety of shapes
- ✓ Cost saving
- ✓ Fast

www.cgm-srl.com - info@cgm-srl.com

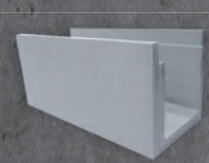



Hobby Center and Tranquillity Park 2017



Hobby Center and Tranquillity Park 2021



City Hall 2017



City Hall 2021

The 13-block Bagby Street is located in Houston's Midtown District, one of the city's largest and oldest central neighborhoods. As the city grew and became increasingly industrialized during the 20th century, multi-lane roads to the center were needed to accommodate the massive surge in traffic. Since then, Houston's working and living patterns have undergone a transformation, with numerous residents combining their living and working centers within midtown. Consequently, one of the greatest challenges for reconstructing the street was to remove its "drive-through" character and make it more pedestrian-friendly.

The project design combines the needs of current demographics with transportation planning in this heavily trafficked area of Houston, providing a wide pedestrian area on both sides of the street and a two-lane bike lane on the east side. It also includes the installation of gardens as well as better access to Midtown Park and local businesses. This is because approximately 40% of Houston residents do not drive within the city.⁷ As such, Bagby Street serves as a prime example of sustainable street design that combines public transit, travel and pedestrian areas with crosswalks to downtown, reflecting all aspects of modern infrastructure.

Consideration of regional requirements in terms of the product properties of concrete block systems

Since Wausau Tile has already been involved in several other projects in Houston, the company is familiar with the region-specific requirements of the city's infrastructure and can take these into account in the product properties of the desired paver and slab systems. This includes defining the stone formats, concrete formulation and project-specific color selection.

SWA designed rectangular pavers in herringbone installation for the pedestrian area. As cooler shades are currently becoming prevalent in the Houston cityscape as well, light to dark shades of gray are used for this area, resulting in a varied installation pattern. The use of black hexagon bricks in the design of the bike lanes creates a distinct contrast, as there are only visual barriers to the sidewalks in the traffic pattern.

SWA and Wausau Tile held several meetings to refine the product mix and were able to customize the aggregates after determining the necessary stone formats. The next step was to determine the individual colorations of the stones in detail and in combination with each other. Sample stones were produced and evaluated in a test laying at Wausau Tile. The development phase took about 14 months, and construction began in 2018.

Similar to the Miami Worldcenter project, products were shipped thousands of miles from Wisconsin to Texas - thanks to Wausau Tile's intensive cooperation and quick responses combined with the concrete blocks customized for the Bagby Street's project conditions.



Bagby Street: Stone installation pedestrian and bicycle area



protected by
DE 20 2015 102 814

UPadvanced

PRODUCTION PALLET

PRODUCED FROM SOLID WOODEN CORE
AND PLASTIC COATING ON BOTH SIDES



UPplus[®]

PRODUCTION PALLET

PRODUCED FROM SOLID WOODEN
PLANKS WITH DOUBLE DOVETAIL JOINTS



The approximately 117,000 square feet of concrete blocks were installed in block layers using machine installation on thinset. Because of differences in level within the overall area, different stone heights are installed. More than 50% of the area has already been completed. The project is scheduled to reach completion in May 2021.

The right mold technology for every concrete block product

For this project, all concrete blocks are manufactured in Basicline2™ molds from Kobra, which are characterized by a clear design consisting of an insert made of block material with circumferential chamber geometries to accommodate the flange assemblies including the running rails. This design prevents any unnecessary welded joints in and on the insert. The mold insert and cover plates have a hardness standard of 68 HRC and a hardening depth of 1.2 mm.

The upper part of the Wausau Tile molds are equipped with Headguide and Hotshoe.

The use of Basicline2 for the Bagby Street project is due to the format of the pavers and the number of cycles planned with the product.

Stone Technology

The exclusive four-color blend creates unique color gradients and complete creative control to customize color palettes. Wausau Tile has more than 73 molds (H-Series) and 74 different mold combinations of sizes and thicknesses (V-Series), making it possible to offer a perfect fit for every job and develop custom colors and sizes. All Wausau Tile pavers are rigorously tested and manufactured to meet the industry's tightest performance tolerances. Using state-of-the-art manufacturing technology, Wausau Tile's paver systems are produced with unique colors, sizes and custom options.

Wausau Tile has a detailed mold management system that makes it possible to factor in usage for projects, maintenance intervals and wear part changes.

The Wausau Tile product range is truly remarkable - outdoor furniture, terrazzo tiles, a wide variety of precast concrete products, and architectural pavers are all part of the company's repertoire. Regarding the latter category, Wausau Tile builds on more than 40 years of proven history and lives up



Basicline2™ - Hexagon stone mold



Basicline2™ - Paver mold

60

YEARS OF INNOVATION

WASA®

Competence Leadership.

Maximum performance – every minute of every hour of every day.

Our production runs 24 hours a day, seven days a week, and at the highest level. Benefit from production boards which enable the creation of excellent concrete products. Whether in terms of load-bearing capacity, precision or value retention, our broad portfolio has the perfect product for your application – whatever you need.

✓ **WASA UNIPLAST® ULTRA**

The high-performance board made from all-plastic, glass-fibre reinforced material for the most demanding applications.

✓ **WASA WOODPLAST®**

The best of both worlds: the composite board made from polyurethane and a strong wood core.

✓ **WASA SOFTWOOD**

The proven softwood board with impressive production characteristics at low investment costs.

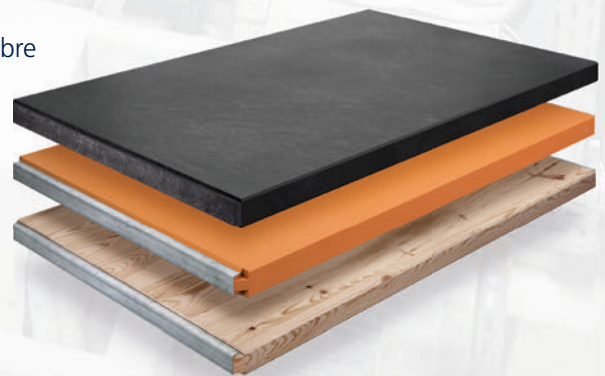

WASA BOARDS

Mold Technology

Kobra has adapted its entire manufacturing processes towards a modular design, thus combining multiple advantages that cannot be realized in the same mold types in a welded design. This starts as early as the development of the stone and the constructive implementation of the layout required by the customer and continues through all the stages of a mold's life to the repair and reuse of mold parts.

Boltline™

Boltline technology relates to the design of the insert. Concrete block molds manufactured with this technology therefore adopt the module idea not only in terms of the frame, but also of the insert. All components of the mold base can be individually repaired or replaced.

The cost-efficient production of concrete products is supported and flexibility in production is increased with the targeted replacement of assemblies that wear out more quickly while continuing to use the mold parts that can be used multiple times.

Facts & benefits:

- Applicable to different types of inserts, such as straight or mixed layouts
- Frame bolted and reusable
- Lower tolerances on angularity, straightness and deviation of body edges than required by DIN 1339/1338.
- Replaceable wear plates bolted onto the mold frame

Basicline™

Basicline molds have a clear design structure consisting of an insert made of block material with different frame variants. This technology is used to produce classic concrete block molds for the production of paver systems, which are dimensionally stable and particularly wear-resistant with the Kobra quality standard Optimill carbo carbo 68 plus.

Facts & benefits:

- Special cavity geometries for uninterrupted hardening
- Hardness quality up to 68 HRC, hardness depth up to 1.2 mm
- Multiple insert changes possible in the old frame

Headguide™

Headguide ensures absolutely correct and centered installation of the overall mold in the machine and thus

protects particularly sensitive mini chamfers on large-format tamper shoes. The guide pins of the positive centering system ensure precise insertion of the tamper head into the mold bottom. With an all-round clearance of two tenths mm, the mold can move freely, but remains guided at all times. Wear of the tamper shoes and the top edge of the mold is minimized significantly, and the metal abrasion is almost completely prevented in the mold.

Facts & benefits:

- Bolt and bushing can be replaced as wear parts
- Ensures centered installation of the entire mold in the machine
- Protects sensitive mini-chamfers on large-format products
- Reduces wear on the upper edge of the mold

Hotshoe™

With Hotshoe, which consists of heatable tamper shoes and an integrated temperature control device, verifiably higher surface qualities can be achieved on the concrete block. The drying of the facing concrete prevents the tamper shoes from adhering to the concrete and helps with the texture of the block surface. Higher surface qualities and a refined finished surface appearance are achieved.

Facts & benefits:

- Verifiably higher surface quality on the concrete block, fewer rejects
- The temperature range with the Kobra control device can be controlled for customer-specific and individual product needs
- Prevents the adhesion of moist, fine facing concrete through controlled setting
- Shorter cycle times for products requiring intensive cleaning

Flexshoe™

Flexshoe is a useful compacting aid, especially for large format products and special formats. The tamper shoes are mounted on rubber supports which ensure improved compacting results and higher block surface qualities. »Flexshoe™« prevents uneven lifting up of the tamper shoes from the block and ensure optimum tamper shoe clearance due to the damping effects in the tamper head.

Facts & benefits:

- Improved compaction results for large and difficult to compact products
- Optimal vibration utilization in the cavity
- Consistent block height and perfect surfaces
- Higher damping effect and tamper head stability

to its self-imposed standards of service and quality in each and every one of its numerous design and architectural projects across the United States. The diversity of Wausau Tile's pavers and the products that can be customized according to the building project, as well as the professional competence of the team, are decisive factors for the company's success. The projects presented in this article are just two examples of the outstanding market position that Wausau Tile holds in this sector of the industry. They are a vivid demonstration of the significance of concrete block products in urban development projects and how important they are, not only in terms of functionality but also in terms of their design, for the development of new urban districts and streetscapes.

References

- ¹www.wausautile.com, accessed: 15.03.2021
- ²www.miamiworldcenter.com, accessed 16.03.2021
- ³www.kimley-horn.com, accessed 16.03.2021
- ⁴www.squareedgeinc.com, accessed 16.03.2021
- ⁵www.swagroup.com, accessed 22.03.2021
- ⁶www.transportation.gov, accessed 22.03.2021
- ⁷www.houstontx.gov, accessed 22.03.2021



Kobra sponsored the free download possibility of the pdf of this article for all readers of CPI. Please check the website www.cpi-worldwide.com/channels/kobra or scan the QR code with your smartphone to get direct access to this website.



FURTHER INFORMATION



Wausau Tile Inc
9001 Bus. Hwy 51
Rothschild, WI 54474, USA
T +1 715 3593121
F +1 715 3554627
wtile@wausautile.com
www.wausautile.com



Kobra Formen GmbH
Plohnbachstraße 1, 08485 Lengenfeld, Germany
T +49 37606 3020
F +49 37606 30222
info@kobragroup.com
www.kobragroup.com



PERI Pave 2.0 The new standard

Do you already know the new generation of PERI Pave production pallets?

Thanks to the unique plastic coating, concrete sticking belongs to the past.

The PERI Pave production pallets are equally convincing in terms of load-bearing capacity, surface hardness, abrasion resistance and vibration behaviour while, at the same time, having a relatively low own weight.

Interested? We are pleased to inform you!

Formwork Scaffolding Engineering
www.peri.com/pave

