

Kobra Formen GmbH, 08485 Lengenfeld, Germany

## Modular mold construction: bolted concrete block molds can decisively influence production planning

The worldwide number of manufacturers of high-quality molds for the concrete block industry is rather modest – concrete block molds are a niche product. As in every industry there are fundamental corporate philosophies that directly influence the product to be manufactured. In the case of concrete block molds, a clear line can be drawn between welded and bolted technologies. Kobra Formen GmbH has aligned its entire production process to a modular construction with inserted/bolted elements and thus occupies a special position amongst mold manufacturers.

■ Holger Stichel | Stefanie Schaarschmidt, Kobra Formen GmbH, Germany ■

The modular construction of concrete block molds has numerous advantages that cannot be realised with the same mold types in a welded version. This begins with the development of the stone and the structural implementation of the customer's desired layout and extends over all the stations in the life of a mold up to the repair and reuse of mold components.

Kobra has built the entire product and brand structure on the basis of the bolted mold construction, an overview of which is given in the following article.

### Standard mold construction and a view to the future

Kobra began with flamecut and polished inserts. Cover plates and frame parts were permanently welded to the insert block in this design. The segments of the mold upper part – tamper head and

tampershoes – were also welded. The repair of individual components was only possible to a limited extent here. In case of wear the complete mold usually had to be disposed of.

Since the concrete block mold, as a tool, functioned in this context as a disposable product with which enormous capital is tied up with high investment sums, Kobra developed concepts for a sustainable and thus economic use of the mold.

The objective was to ensure the reparability of the mold and the reuse of individual components and assemblies in order to support the cost-efficient manufacture of concrete products and to increase flexibility in production – it was the birth of modular mold construction.

The basic idea was to design the mold to allow the replacement of the faster-wearing assemblies without having to replace the mold components that are still usable. If components are welded together

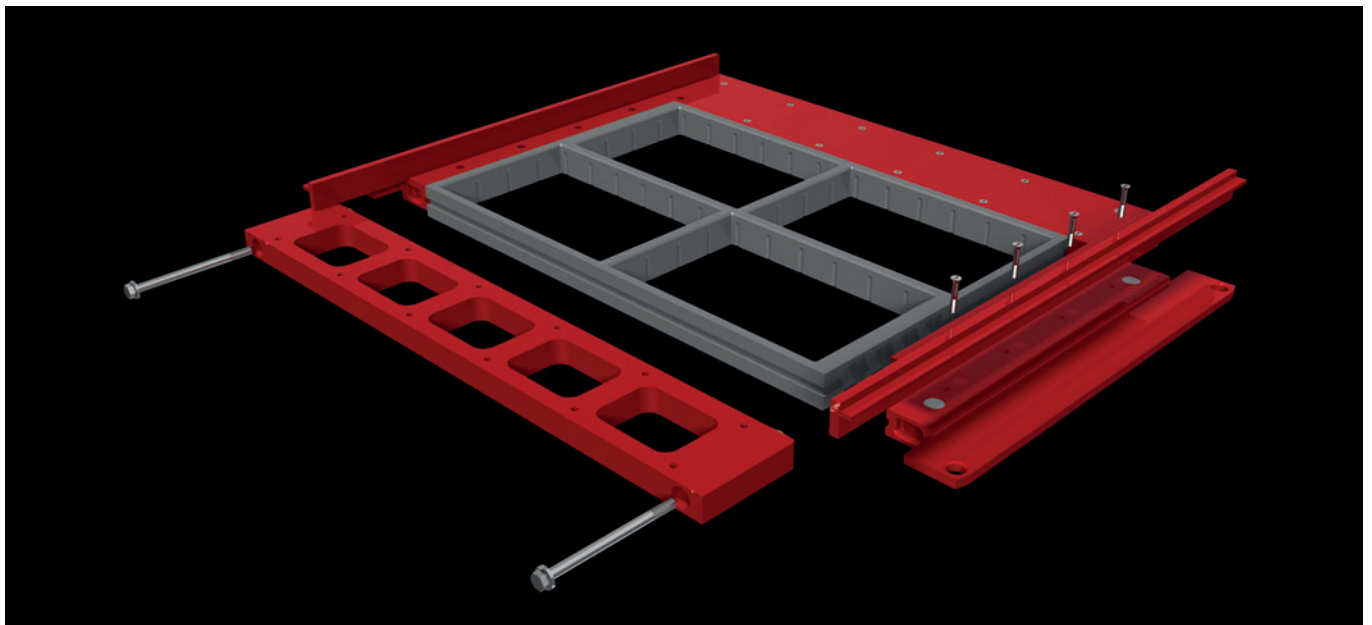

*Exploded view of a Moduline1 frame*

er, the replacement of individual components is possible only with great difficulty. Therefore, Kobra chose to consistently use inserted/bolted elements and has aligned the design of all mold types, regardless of whether they were flat or high, to this method of construction.

### Modular construction in the mold body

#### The Moduline™ series from Kobra

Moduline molds is the name given to different frame variants that are bolted around a completely CNC-milled (not flame-cut!) and hardened insert. All mold inserts are hardened in Kobra's own tempering furnaces and are given the label Optimill carbo 68 plus. Optimill stands for the milling process that guarantees precise angularity in the stone field, and carbo 68 plus for the surface hardness of 68 HRC. Kobra manufactures its mold inserts exclusively in this hardness quality. As a result, not only is the disproportionately high surface hardness mentioned above achieved, but also a depth of hardening depth of 1.2 mm all around.

Depending on the concrete block product to be manufactured, there are different frame variants within the Moduline series that can be installed. All frame types are based on the idea of fast and uncomplicated insert replacement. One frame for different inserts.



Moduline2 – view of a complete mold

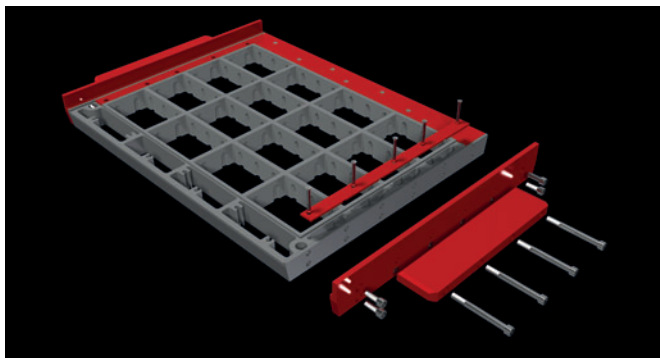

Exploded view of a Moduline2 frame

# Handling your future

- Handling equipment for production plants
- In-line and Off-line aging systems with quality check for every piece
- Secondary surface processing machines
- Custom designed equipment solutions



# PENTA

AUTOMAZIONI INDUSTRIALI SRL

Via Aldo Moro, 32 - 40062 Molinella (Bologna) - ITALY  
 Tel 0039 051 880550 - Fax 0039 051 881386  
 sales@penta-automazioni.it - www.penta-automazioni.it

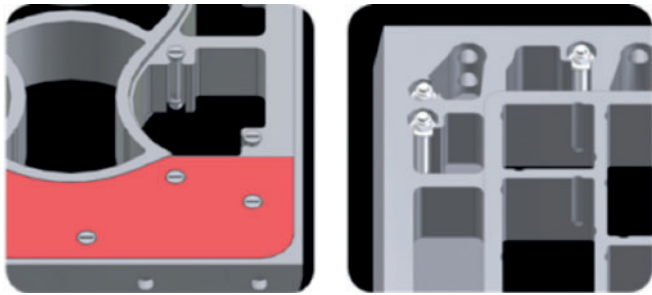

*Detailed view of the Feature Longlife – all-round empty fields for constant hardness in the mold insert*

This option is available to Kobra customers both in the case of repair and for the planned exchange of inserts for the manufacture of different products.

Moduline1 is the name given to an insert/frame connection with tongue and groove and includes only four bolts. The frame corners are reinforced by a polygonal profile. The frame has four parts, while the cover plates are also bolted and can be replaced separately.

The mold body of a Moduline2 mold consists only of three components – the insert, the flanges and the cover plates.

The flange assemblies are connected horizontally to the insert by means of fitting bolts. So that the high hardness of the insert mentioned above is not interrupted, it also has a special all-round cavity geometry, which Kobra designates Feature Longlife™ and which is located between the stone cavities and the frame elements. The highly hardened and tempered cover plates are also bolted to the plinths of the empty fields and, as with the Moduline1, can be replaced with little effort. The flange assembly, on the other hand, can be used several times.

Unlike the other design variants with this technology, Moduline3 has a stable one-piece frame that is bolted vertically to the insert. Inserts and wearing parts such as the cover plates are replaced, while the frame is reused several times.

#### Basic components of the concrete block mold for universal use

The Moduline3 in particular is suitable for Kobra customers for the optimisation of their mold store, since the assembly of the basic mold components together with the replaceable components is particularly easy to do. The system explained below is in principle also usable for Moduline1 und Moduline2. For a more detailed explanation it is necessary to take a look not only at the mold body described so far, but also the entire mold:

The mold upper part consists of a reusable tamper head adaptor, with which tamper head sections can be combined for the manufacture of different stones. The mold body contains the frame as a constant component that can accept changing inserts.

The resulting product variations can make for enormous cost savings and high flexibility in production. Numerous Kobra customers use this system successfully and even use the same basic mold components at various production locations.

#### The Dynamic™ series from Kobra

The Dynamic technology is the name given to a further frame variant from Kobra. On the outside of the insert there are trapezoidal shapes via which the vibrating liner is clamped in the four-piece bolted frame by means of rubber bearings. This enables free and

defined vibration behaviour of the insert. In the compaction process only the mass of the insert is accelerated and vibrates with a frequency and amplitude several times higher than that of the frame. This principle results in a very good introduction of force into the concrete and provides for very good lateral surfaces on the stone. The better compaction behaviour results in considerable advantages in the manufacture of flat products and products that are difficult to fill.

Here, too, the cover plates are highly hardened and tempered and are easy to replace as wearing parts thanks to their bolted connection. The frame is reusable following an insert replacement.

#### The Boltline™ series from Kobra

The Boltline technology refers to the design of the insert. Concrete block molds manufactured with the Boltline technology thus adopt the modular concept with respect not only to the frame, but also to the insert. All the components of the mold body are individually repairable or replaceable.

Boltline1 is used for all high products such as hollow block, solid block, kerbstone or radius kerbstone molds. The insert is made of individual walls that are inserted into/bolted to one another. Apart from the aspect of flexible production planning, which is the main thrust of this article, a further advantage results. Thanks to the modularised manufacture of individual walls, the steel consumption is reduced by around 70% compared to the manufacture from block material and the CO<sub>2</sub> emission is thus also reduced by around 50%. The insert can be combined with the Moduline1 and Dynamic frame variants, so that a four-piece bolted frame is always used which, in turn, is usable several times. The cover plates are also bolted and thus easily replaceable.

In the case of hollow block molds the modular concept is continued through to the core assembly. It consists of individual elements that are bolted together. If one core is defective it can be replaced with no great effort.

Boltline3 is used for the manufacture of paving stone and slab systems from an edge length of 300 mm upwards. The Boltline3 insert provides for the connections of the individual walls with bolts. All inserts are completely milled and thus exhibit precise angularity in

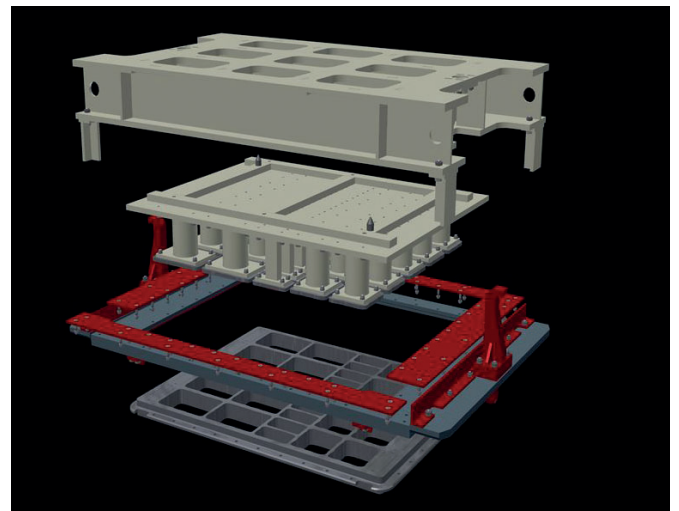

*Replaceable mold components provide for high production flexibility*

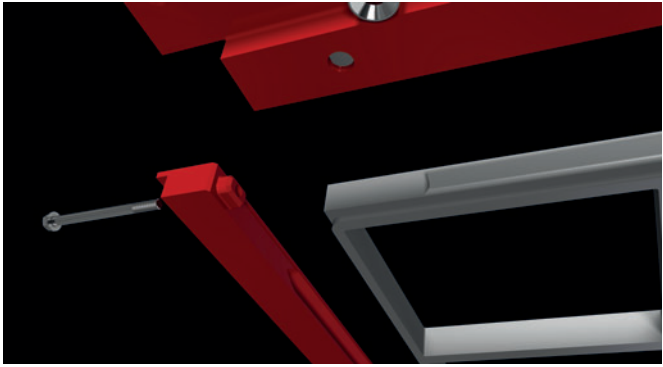

Exploded view of a Dynamic frame

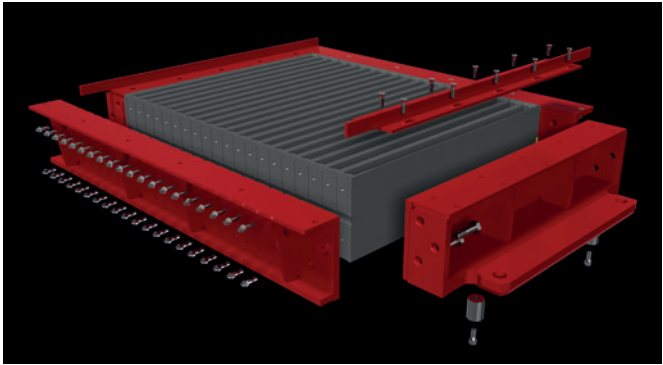

Exploded view of a Boltline1 mold body for the manufacture of kerbstones

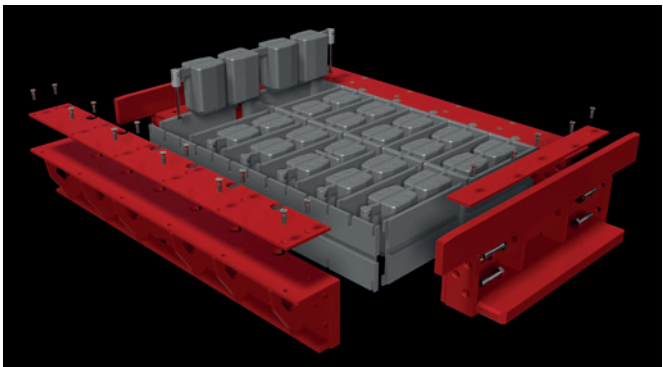

Exploded view of a Boltline1 mold body for the manufacture of hollow blocks

the stone field with the previously mentioned surface hardness of 68 HRC and a homogeneous depth of hardening of 1.2 mm. The tightest tolerances can be achieved in surface diagonals, straightness and angularity that fall well within the German and European DIN standards. Boltline3 inserts can be combined with Moduline1, Moduline3 and Dynamic frames.

#### Modular construction in the mold upper part

The idea of the construction kit system is also utilised in the mold upper part. Kobra molds have generally been equipped with Singlebolt™ bolted one-piece tamper heads since 2004. These

#### HP800

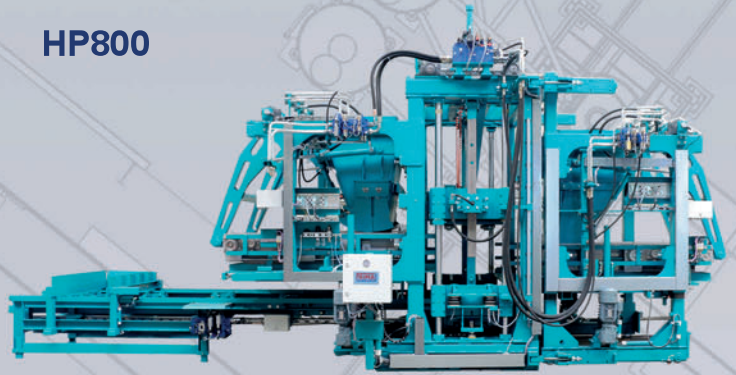

#### HP1400

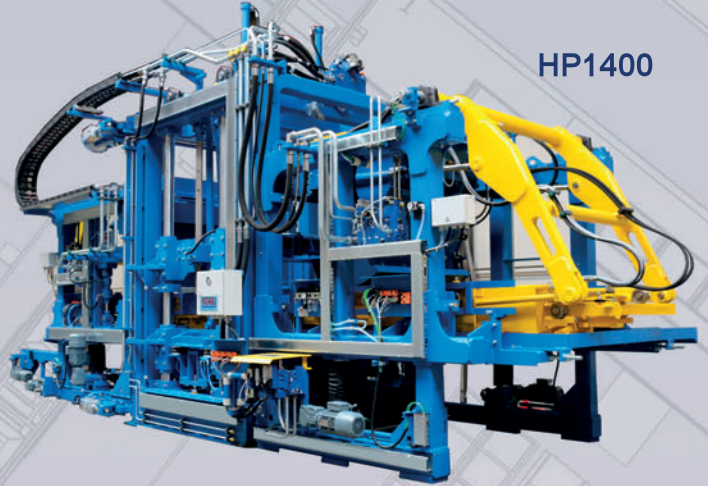

#### P650



#### Specialist in:

- concrete block plants
- mixing and batching technologie
- robot-controlled customized plants
- paving stone treatment systems



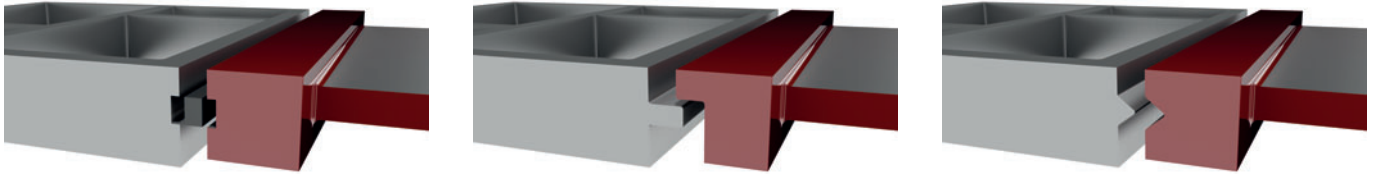

Frame variants Moduline1, Moduline3 and Dynamic for Boltline3 molds

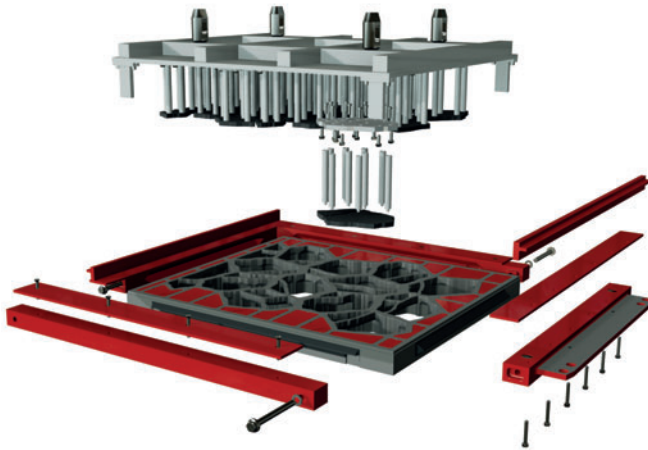

Exploded view of a Dynamic mold with Singlebolt one-piece tamper heads

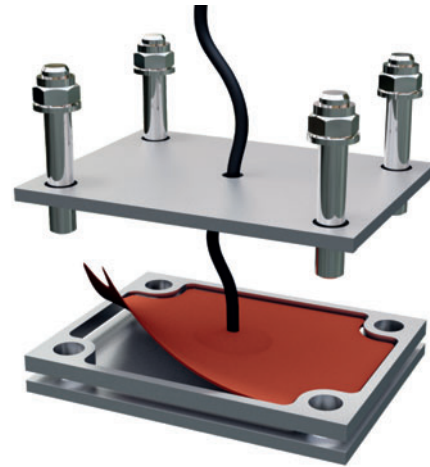

Structure of a heated tamper shoe

enable the very good introduction of the vibration forces into the upper part of the tamper head and are easily accessible and individually replaceable in the case of repair.

The integration of additional equipment, the so-called features, is also facilitated by the modular system. As compaction and demolding aids, Kobra offers the features Hotshoe™, compact sandwich elements with flexible heating mats, and Flexshoe™, stop plates on rubber bearings for homogeneous block heights and minimised crack formation on the stone surface.

The Headguide™ – forced centring of the mold body to the tamper head – is also optionally available. The tamper shoe play and thus the wearing of the components are considerably reduced. Not only that, delicate surfaces and a chamfer that is evenly formed all around can be achieved.

The technologies shown here reflect only one part of the Kobra production range and were selected in order to explain the system that lies behind a Kobra mold. Concrete block molds are manufactured individually. The suitable technology and the additional equipment that is most useful for the concrete block to be manufactured are therefore determined in close consultation between Kobra and its customers. ■

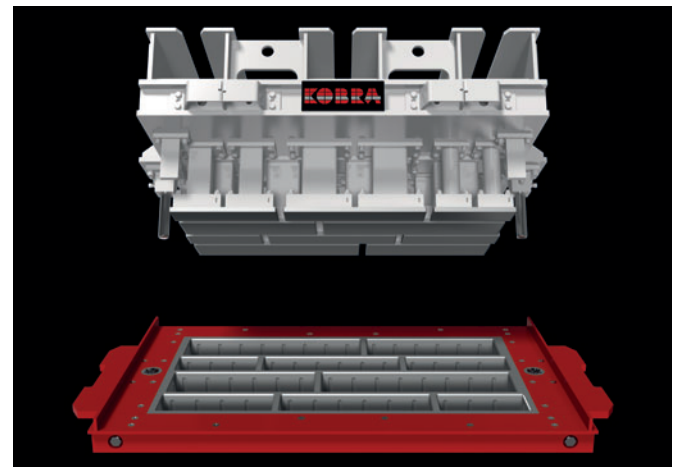

Illustration of a complete Boltline3 mold with Headguide forced centring



Kobra sponsored the free download possibility of the pdf of this article for all readers of CPI. Please check the website [www.cpi-worldwide.com/channels/kobra](http://www.cpi-worldwide.com/channels/kobra) or scan the QR code with your smartphone to get direct access to this website.



**Kobra Formen GmbH inaugurates new training workshop**

Kobra Formen GmbH is one of the global market leaders in the development and manufacture of concrete block molds and trains its own young talent. It has been doing so for over 20 years, and for more 10 of those years with its own training workshop.

The floor area of the new training workshop has been more than doubled and equipped with state-of-the-art machines. The best possible boundary conditions have been created for a success career start for the current 29 apprentices in the professions of cutting machine operator, design mechanic, industrial mechanic and electronic technician. Kobra has invested 250,000 EUR in the expansion of its in-house training – an investment in the future, because Kobra trains people in order to employ them. 54 of the current 300 employees at the Lengenfeld site have completed an apprenticeship at Kobra and most of them are specialists and managerial staffs.

Apart from the manufacturing-related apprenticeship professions, Kobra also offers apprenticeships for technical product designers and is a practical partner for courses of study in international management, computer engineering or business informatics, mechanical engineering and production technology at the vocational academies in the state of Saxony.

Holger Stichel, managing partner of Kobra, summarises once again: "We are so successful on the international markets because our products meet the highest standards and we are constantly developing them. That is possible because the outstanding training of our technical personnel and the associated know-how flows directly into our product."



Overall view of the Kobra training workshop



Insight into practical training at Kobra

**FURTHER INFORMATION**



Kobra Formen GmbH  
Plohnbachstraße 1  
08485 Lengenfeld, Germany  
T +49 37606 3020, F +49 37606 30222  
info@kobragroup.com, www.kobragroup.com

**ASSYX DuroBOARD® production boards**

- X** high quality materials
- X** high precision processing
- X** high competent service

Increase your productivity and improve the quality of your concrete building materials. Increase your range of products. Giving many years of constant and outstanding quality.

**Quality to the power of three.  
Reliable. Worthy. Just good.**



THE BOARD THAT REMAINS.  
The ASSYX DuroBOARD®. The best support for your production of concrete blocks and pavers.

**ASSYX – The Original.**

**www.assyx.com**

ASSYX GmbH & Co. KG · D-56626 Andernach  
Phone: +49(0)2632 - 94 75 10 · Fax: 94 75 111