

Kobra Formen GmbH, 08485 Lengenfeld, Germany

Technical innovations for high-quality concrete products

Concrete block moulds from Kobra Formen GmbH have been manufactured for many years using the proprietary »carbo™« hardening technology. In close co-operation with concrete block manufacturers all over the world, methods of construction and technologies are constantly being developed in order to increase the service lives of the moulds. That also includes the improvement of the resistance to wear of the individual mould components, which are subjected to particular stresses during the filling and compacting process. Therefore, spanning technologies, Kobra offers not only mould liners, but also bolted cover plates in »carbo 68 plus™« quality with an impressive degree of hardness of 68 HRC and a hardening depth of 1.2 mm.

Comprehensive service for concrete block moulds still includes after-sales customer support and service. Kobra Formen GmbH's range of services also includes repair and service directly on-site at the concrete block works or at the Lengenfeld Service Centre.

■ Holger Stichel, Stefanie Schaarschmidt,
Kobra Formen GmbH, Germany ■

Innovative methods of construction – history and technical background

The technical development of concrete block moulds has made great progress in the past 20 years. In the beginning, special steel alloys were used for the burnt-welded construction method in order to increase the resistance of the moulds to wear. Kobra was the first mould maker in the industry to switch its production completely to milling technology and thus to improve the accuracy of the dimensional tolerance of the stones from the previously usual 1.5 mm to a few tenths of a millimetre. Additionally Kobra developed modular construction methods for concrete block moulds, which are characterised by clear design structures and enable the combination of different Kobra technologies in a single mould.

The engineering of new construction methods depended primarily on market demands; moulds used in the manufacturing of concrete blocks needed a higher resistance to wear and must be easier to repair. This necessitated new hardening techniques for the steel employed as well as innovative mould construction methods. Kobra's task was to combine the various market demands as well as to adhere to applicable industrial standards and tolerance ranges for the production of concrete block products of all kinds.

The carbo™ hardening method – for increased resistance to wear

The carbo™ hardening method has been used at Kobra for around 15 years. Initially it was possible to significantly improve the resistance to wear of paving stone moulds. Two years later it also became possible to manufacture wearing parts for the »Boltline™« product group in carbo™ quality. This group of moulds also included moulds for hollow blocks and kerbstones. The normal service life for gasnitrided hollow block moulds up to that point had been around 80,000 to 120,000 cycles. The improved product quality can be demonstrated particularly well taking the example

of concrete block production in the Middle East, which in some cases use highly abrasive material with granite content and steel production boards in the manufacturing process and in which the wear of the concrete block moulds was excessive. Kobra supplied the first carbo-hardened hollow block mould with replaceable wearing parts to the United Arab Emirates at the beginning of 2004, almost doubling the service life to over 200,000 cycles. Part of the company philosophy of Kobra Formen GmbH is the continuous development of successful manufacturing methods that are established on the market. The carbo hardening method was thus also subjected to numerous further tests until, in

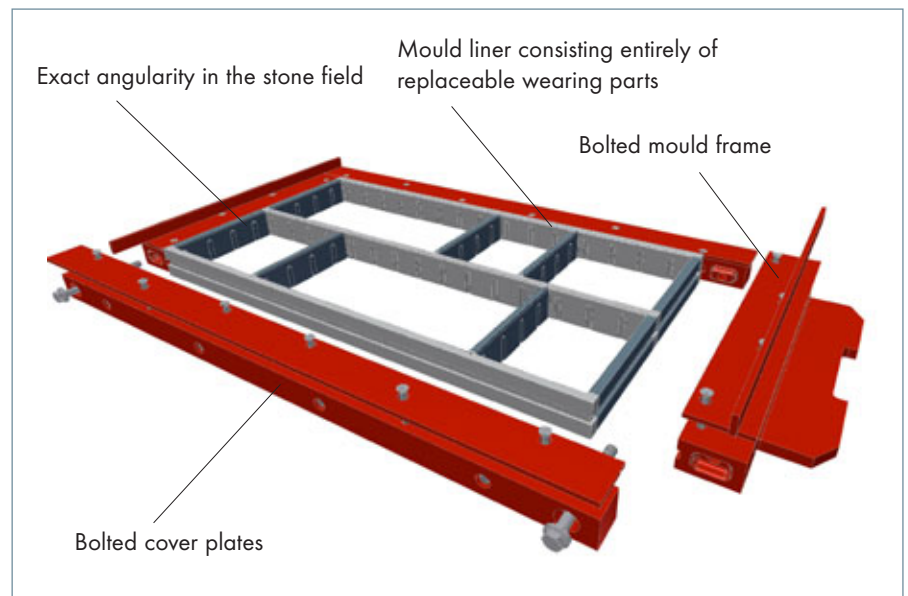

Figure 1: Modular construction method of a Kobra concrete block mould

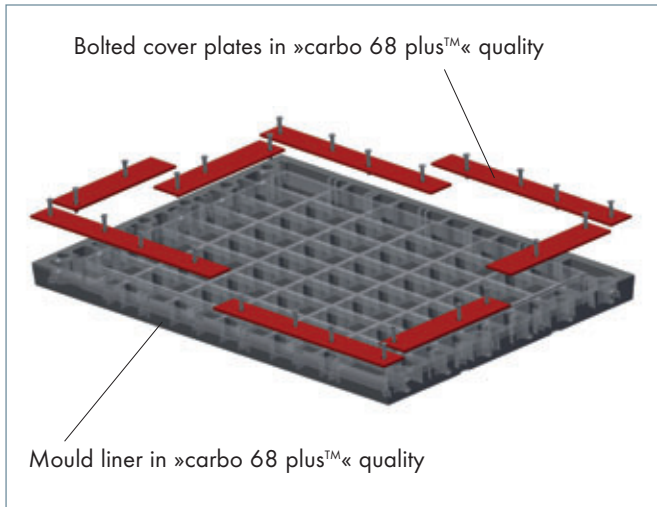

Figure 2: Bolted cover plates in carbo 68 plus quality

2009, »Optimill carbo 68 plus™« was defined as the new product standard for paving stone moulds from Kobra. This new quality is characterised by a hardness quality of 68 HRC and a homogeneous depth of hardening of 1.2 mm in the mould liner, which can lead to a considerable increase in the service life of the moulds, taking into consideration the prevailing production parameters. The precisely milled stone fields enable maximum accuracy, smooth surfaces and straight mould walls.

Kobra was able to realise a further leap in quality with the application of the carbo 68 plus manufacturing process. This process applies to the large-sized paving and slab systems with edge lengths of up to 1,250 mm that are particularly popular in Europe and North America. Hundreds of moulds of this type are successfully in use at present.

The modular construction method – for faster and simplified repairs

Apart from increased resistance to wear, Kobra has also continuously developed the modular construction method for different product groups on the basis of an individual part concept. For example, the mould liner of a »Boltline 3™« mould, which is used for the large-sized products mentioned above, consists entirely of plug-in/bolted individual parts which are thus replaceable. The frame construction and the cover plates are also bolted and individually replaceable. In addition, there is the option to combine features from the complete range of Kobra technologies, such as »Hotshoe™« for heated shoes, »Headguide™« for the protection of particularly sensitive minichamfers or »Flexshoe™« for improved compaction of the facing concrete.

The combination of modular constructions and wear-resistant technologies – for long service lives and high product quality

While inspecting and repairing moulds that were already in use in the concrete block plant, the Kobra service team noticed a considerable reduction in the typical signs of wear on the mould liner, but not on the cover plates. During the filling process the cover plates that form the upper closure of the frame are particularly subject to stress, since the feed box drives over the mould.



NEW

bolted wear plates in »carbo 68 plus™« quality

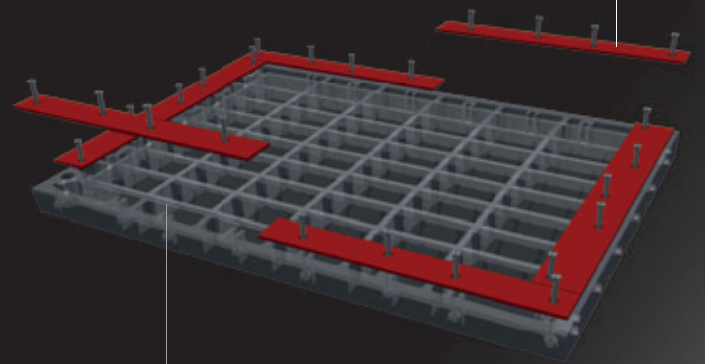

mold insert in »carbo 68 plus™« quality

Hardness - Dimensional Accuracy - Wear Resistance

By combining both mold insert and wear plates in »carbo 68 plus™« quality, you achieve the highest efficiency in your manufacturing process and a significant improvement in the molds' service life. With milled cavities in the mold insert, you also benefit from perfect straightness and angularity.



KOBRA. We make the mold around your stone.

Detailed information can be obtained from our sales team.

Being subjected to the same level of stress, it became apparent that the liner showed less wear than the cover plates on account of its higher degree of hardness. Therefore, with the aim of a continuous improvement in the service lives of the moulds, the possibility of also using the carbo 68 plus hardening method on the cover plates was checked. This year Kobra was able to deliver the first moulds with both liner and cover plates in carbo 68 plus quality and they already exhibit a considerably higher number of cycles without the necessity for replacement of wearing parts.

Support on Site – purposeful measures for the extension of the service lives of concrete block moulds

Many concrete block producers use the option of having minor damage to the mould repaired directly at their factory in order to avoid transport costs and lengthy downtimes in production. Kobra’s »Support on Site™« service provides numerous repair options to extend the service life of concrete block moulds such as:

- Welding of cracks in the liner, frame or tamper head
- Welding or replacement of broken plungers
- Repair of chipped or damaged chamfers
- Replacement of worn pressure plates (shoes) or core assemblies
- Reconditioning of the lower edge of the mould
- Liner replacement in the case of bolted mould constructions

- Start-up service for heated special forms

Repairs at the Lengenfeld Service Centre

If the mould repair demand exceeds the measures listed above, it is recommended to have a thorough inspection carried out at the Kobra Service Centre, which is directly connected to the main production in Lengenfeld. A comprehensive check of the mould is initially carried out on the basis of wear patterns and the steps necessary for an economically worthwhile repair are defined.

All necessary information and data on the history of a mould manufactured by Kobra can be completely retraced and repairs can be carried out using Kobra manufacturing quality standards. Before commencing with the repair, the customer receives a detailed quotation for the work to be carried out:

- Cleaning and inspection of each mould to determine the actual repair needs
- Welding of the lower edge of the mould
- Pressure plate (shoe) replacement including fitting and mounting
- Welding of cracks in the frame and tamper head
- Replacement of individual components on the frame and mould liner
- Reconditioning of bracings and lamellae
- Blanchard grinding of tamper heads and mould bottoms
- Overhaul of hydraulic and heated moulds



Vibration measurement for the optimisation of process and machine settings

- Reconditioning of running rails
- Conversion of complete moulds to other machine types
- Painting and assembly of each mould

Services for high-quality concrete block products

The Kobra service team’s range of services is not exclusively limited to the repair of moulds, but also includes support for the optimisation of the production process for concrete block products.

My Calibration encompasses detailed advice on achieving the optimum machine setup for the respective mould. This way, process and machine settings can be optimised in order to ensure the manufacture of high-quality products. To do this the dynamic behaviour of the mould in the machine during the compaction process is analysed with up to eight acceleration sensors at the same time. Accelerations, velocities, oscillation paths and frequency spectra are checked and calibrated. The effect also fre-

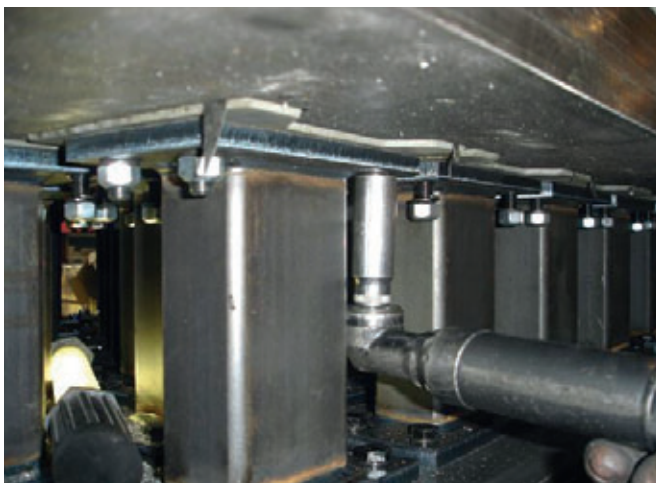

Replacement of bolted single-part tampers.



Pressure plate replacement

The dosing experts!

quently lies in the detail. By means of high-speed recordings, parameters that are important for the production process but barely perceptible to the human eye can be visualised and analysed in order to be able to make corrections to the process settings.

Varying results in the compaction process and differing stone heights can be rectified by using an electrical measuring system to verify the static bar settings. The Kobra service vehicles are equipped with electronic distance measuring devices for checking the static bar tolerances.

Kobra has been developing moulds in accordance with the needs of its customers since 1991. Numerous innovations are the result of close co-operation with concrete block manufacturers all over the world. The combination of intelligent technical solutions and expert support – even after delivery of the mould – will continue to be an important component of the services provided by Kobra in the future.

FURTHER INFORMATION



KOBRA Formen GmbH
 Plohnbachstraße 1, 08485 Lengenfeld, Germany
 T +49 37606 3020, F +49 37606 30222
info@kobragroup.com, www.kobragroup.com

ICC Latin America 2014
 Florianópolis, Brasil
 Stand no. 17

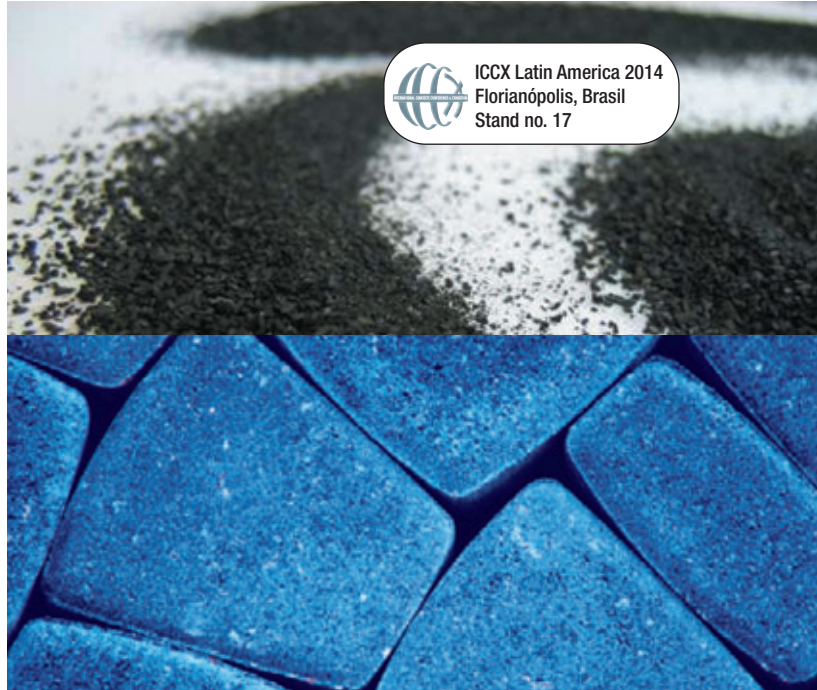

Building material testing machines and equipments



Compression test

Bending test

Tensile test



Choose the Original
 Choose Success!



FORM+TEST Seidner&Co. GmbH
 phone +49 (0) 7371 9302-0
sales@formtest.de
www.formtest.de



Dosing systems for:

Admixtures
 Colours
 Liquids
 Fibres

Powder
 Granules
 Microsilica

Phone: +49 711 448 13 0 · Email: info@wuerschum.com



Phone: +1 603 431 5661
 Email: info@concretebiz.com