

Kobra Formen GmbH, 08485 Lengsfeld, Germany

New mould technology for high dimensional accuracy with large-format paver systems

Design diversity with traffic and pedestrian areas has gained rapidly in momentum in the last few years. Now, alongside natural stone look-alike surfaces, a trend towards large-format paving stones and slabs with edge lengths up to 1,250 mm has been observed especially in Germany and other parts of Europe, but also increasingly in North America. During the past two years, Kobra Formen GmbH has been working on the development of the Boltline 3™ System. At bauma 2013 in Munich, this technology will be presented as a mature, marketable product to be reckoned amongst the new standards in industry. More than 500 moulds of this type are being successfully put to use at the current time. This new system makes high product-related dimensional accuracy feasible, thus ensuring the success story of large-format paver systems in all markets of the world. The growth in market share of concrete products from this family underscores the necessity of the Boltline 3™ mould technology.

■ Holger Stichel,
Kobra Formen GmbH, Germany ■

History

In the early years of concrete goods manufacturing, ground surfacing systems were in existence that complied with minimum specifications. Pedestrian paths, open public spaces and industrial areas were laid using simple oblong and square geometry. Requirements concerning heavy duty interlocking effects were added for industrial applications. It was in this way that paver systems now known on a global scale came into being, such as Behaton, UNI and SF interlocking blocks, which, taken as a whole still up to the present day, are systems with relatively short edge lengths up to approximately 400 mm. Smaller slab formats with edge lengths of 300, 400 and 500 mm were also developed.

Mould designers and makers satisfied these market demands by manufacturing moulds with the firing and welding technologies available at that time. The dimensional tol-

erances they attained were perfectly adequate for both product specifications and the regulations applicable to concrete products. Inaccuracies were to be found in the millimetre range and their causes were related to the technologies: manual processing plus tension and warping in the steel.

Market demands

A trend towards large-format area systems has developed on the market during the last five years. In their projects, architects have been designing large areas with an increasingly puristic appearance for pedestrian precincts, extensive public areas or company premises with and without traffic loads. This has given rise to product edges of 600, 800, 1,000, and even of 1,200 mm in length in conjunction with ongoing developments with spacing and interlocking functions. Product thickness has increased from the customary 60 to 80 mm of paving stones to as much as 180 mm. Installing these new systems has presented new chal-

lenges for laying technology as they can only be set in place with vacuum or grab techniques. Specifications in respect of both nominal width and length, the pattern, spacers and joint dimensioning have in principle remained unchanged.

However, the straightness of the lateral edges, angularity of component edges and surface diagonal deviations have all gained in significance along with the increase in dimensions. These factors have to be taken into account with the products and require that the moulds employed be more accurate and of greater quality.

Regulations

Regulations in force such as DIN 18 501 in Germany have been replaced by others in the European standardisation process. New sets of regulations have been compiled by institutions and associations both at a European level and that of member states. DIN EN 1338 thus originated for all types of densely structured paving stones

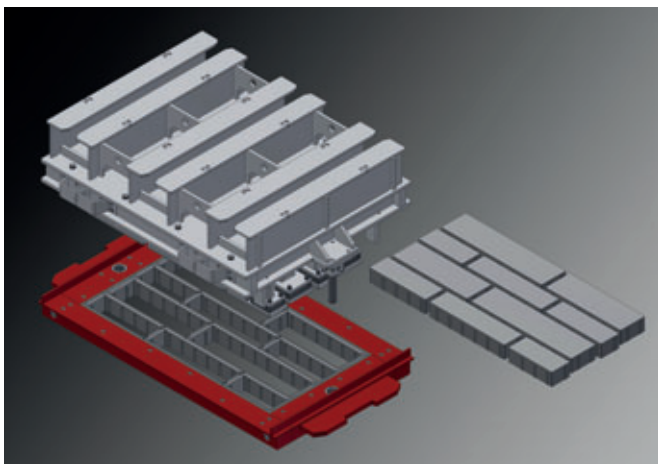

Application example: Klostermann, DECADO multi-block system; object Solar Settlement Münster-Gievenbeck
[mould design: Kobra Formen GmbH, photo: Klostermann]

made from concrete. In the meantime, large-format slabs have to comply with DIN EN 1339.

EU member states have the right to select certain product specifications for application in their own country and to lay these down in national codes of practice. In Germany, this has been regulated by means of the recently created "TL Pflaster-StB". These three sets of regulations form the legal basis for German manufacturers of concrete products. The content of these regulations governs basic requirements concerning concrete quality and final properties, such as resistance to weathering, mechanical strength, skid and slip resistance and permissible dimensional tolerances. For Kobra Formen GmbH, as supplier of high-class mould tooling, these standards merely represent minimum requirements in respect of any admissible dimensional deviations.

Large-format paving stones and slabs – permissible dimensional tolerances

If the tooling supplier himself sets superior standards for the quality of the mould being

Extracts from DIN EN 1338 and "TL Pflaster-StB"	
Permissible deviations from nominal dimensions	For a block thickness < 100 mm: length, width +/- 2 mm, thickness +/- 3 mm For a block thickness ≥ 100 mm: length, width +/- 3 mm, thickness +/- 4 mm
Surface evenness ¹⁾	Convex deviation: ≤ 1.5 or ≤ 2.0 mm (depending on measurement length) Concave deviation: ≤ 1.0 or ≤ 1.5 mm (depending on measurement length)
Max. difference between both diagonals (angularity) ¹⁾	Class 2, Marking „K“ ≤ 3 mm
Extracts from DIN EN 1339	
Nominal length	+/- 3 mm
Nominal width	+/- 3 mm
Difference between both diagonals (Class 3, marking "L")	≤ 2 mm (with diagonals ≤ 850 mm) ≤ 4 mm (with diagonals > 850 mm)
Convex curvature (inside micrometre) ²⁾ (deviating from DIN EN 1339, 2003 edition)	≤ 2 mm
Concave curvature (inside micrometre) ²⁾ (deviating from DIN EN)	≤ 1,5 mm

1) only applies to blocks from a certain size, 2) measured at the slab's greatest dimension (e.g. diagonals)

NEW DEVELOPMENT

850 Fully automatic, stationary single pallet machine



CHAMPIONS ■■■
MADE IN GERMANY



ZENITH Maschinenfabrik GmbH
Zenith-Straße 1 · D-57290 Neunkirchen/Germany
Phone: +49 (2735) 779-234 · Fax: +49 (2735) 779-211
info@zenith.de · www.zenith.de

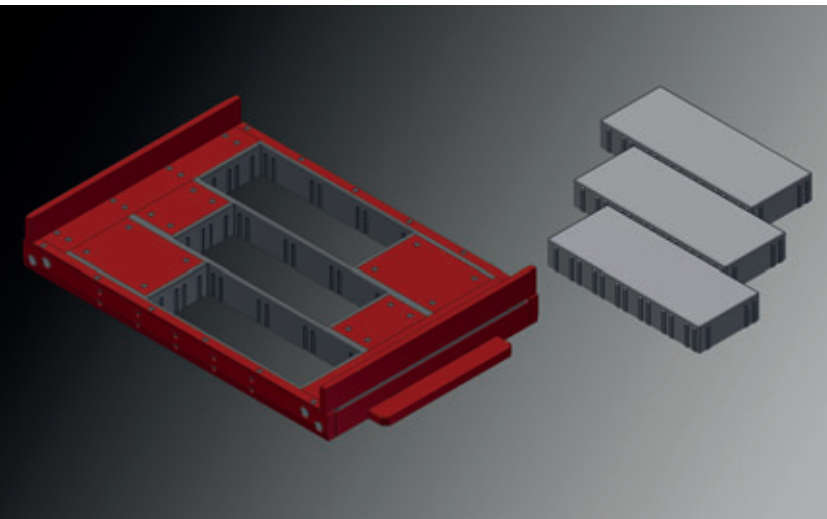

Application example: Godelmann, SCADA rectangular block, object Nordhorn library square [mould design: Kobra Formen GmbH, photo: Godelmann]

delivered, then he is giving the concrete product manufacturer a greater range of tolerance and more reserves in wear resistance when employing the tooling in a production process. The failure on the market of any product family can be prevented right from the start, as safe products are being supplied. Architects and design engineers have at their disposal a product system, which will in turn become more widespread on the market through their own work. In any event, cheap products or “half-hearted” quality counterfeits damage successful market penetration.

Kobra Formen GmbH – standard and implementation

The standard at Kobra Formen GmbH is contained in its mission statement, whereby the team at Kobra will always strive to supply its customers with moulds of the highest quality. Derived from the body of regulations, an internal quality stipulation – the “KN Kobra standard” – has been estab-

lished, which exceeds any specified dimensional accuracy many times over. This means that Kobra is delivering a new industrial standard, which does not just simply suffice minimum requirements. A lower range of tolerances makes manufacturing large-format paving stone and slab systems a market certainty because operators utilising the Kobra mould can produce a pattern, spacer function, joint system and overall area functionality for any occasion, whilst easily and safely complying with dimensional tolerances. Minimum specifications will not be exceeded even with normal wear in the tooling life cycle.

The Boltline 3™ System lives up to this “KN Kobra standard”. It is based on the Optimill Carbo™ System, which has been implemented 100 % by Kobra since the year 2000. Kobra was the first mould supplier in the entire world with this product standard, whereby 100 % of the paver moulds it manufactures have been milled and case-hardened. This foundational quality has been

supplemented by the Optimill Carbo 68+™, a hardening technique developed in house and introduced at bauma 2010. Once again, it highlights Kobra as the only mould supplier who delivers all paver moulds with a 68 HRC surface hardness. This high standard has also been successfully maintained in the Boltline 3™ System. Nowadays, 100 % of all moulds for large-format paving stone and slab systems are produced using Boltline 3™ and Optimill Carbo 68+™ Technology, even with product lengths up to 1,250 mm. For large-format paving stone and slab products, there is no longer any mould manufactured that has been merely fired, welded, nitrided, or just exhibits simple 64HRC case hardening. Kobra customers value the fact that there has been no curtailing of this customary high quality with these new product families as well.

An outstanding feature of the Boltline 3™ product family from Kobra Formen GmbH is, for example, its dimensional accuracy

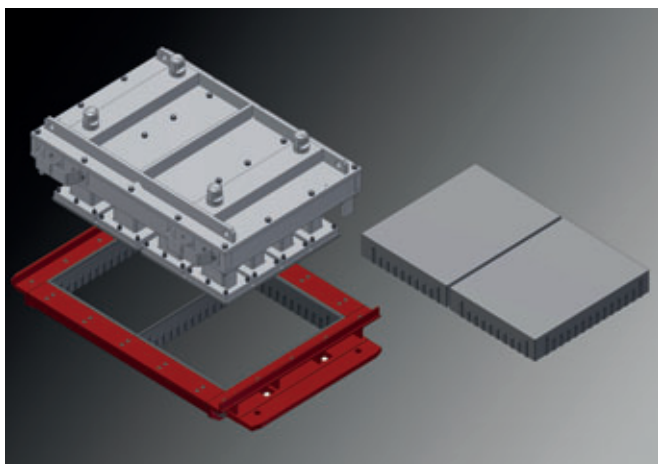

Application example: Rinn, Magnum slab, Object HDI Gerling, Hanover [mould design: Kobra Formen GmbH, photo: Rinn/ ZWP]

with the smallest of deviations in a comparison of two diagonals with large-format, square or oblong, paving stones and slabs. In the case at hand, Kobra Formen can manufacture with a ≤ 0.9 mm deviation of the diagonals to each other. As is indicated in the extracts of the tables illustrated, official regulations specify maximum deviations of ≤ 2 mm, ≤ 3 mm or ≤ 4 mm, depending on product and class. Kobra delivers this quality with every Boltline 3™ mould, regardless of a product's various nominal lengths or class to be achieved. In short, Kobra supplies a quality, which is two, three or even four times better than the standards stipulated for the German market. This means that Kobra is also giving its customers sufficient tolerance reserves for any process-related deviations due to "bulges" in product thickness when utilising zero-slump, instant demoulding techniques.

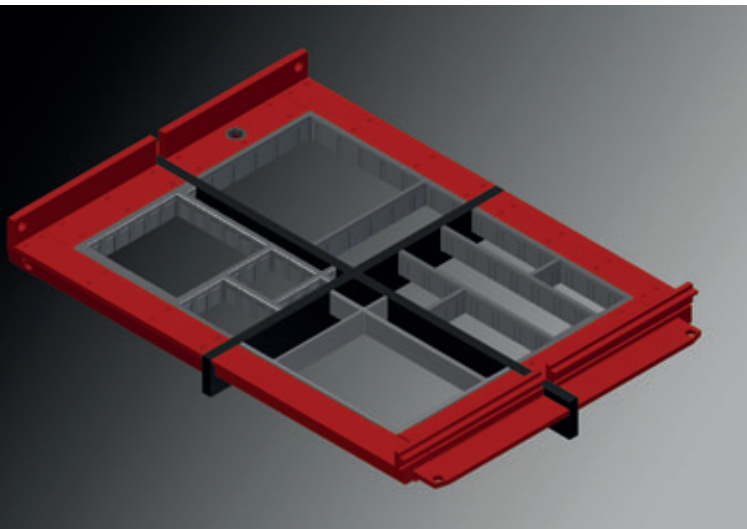

Boltline 3™ Technology for various large-format layout variations

Straightness, angularity, diagonals, concave and convex pressure plate planarity deviation, conicity or opposed conicity, all are governed by the very tight manufacturing tolerances on the Kobra production line. Further Boltline 3™ product characteristics cannot be published in order to maintain confidentiality concerning the innovation. Customers of this technology know its advantages and find them practically indispensable. Evidence of this is the successful completion of more than 500 Boltline 3™ moulds during the last two years and current orders in hand for a further 200 moulds. The quality clearly speaks for itself. And it provides proof of one other matter - there is no demand for minimum specification quality standards and they are shown to be unsuccessful. With the Boltline 3™ System as well, Kobra's mission is to keep on striving for the best possible result with a good price/performance ratio.

The Boltline 3™ System features an intrinsic single component design facilitating an exchangeable replacement part concept in the user's favour, even with great dynamic loading during the manufacturing process. In view of the great market demand, Kobra invested about € 3 million in each of the years 2011 and 2012 in expanding the manufacturing capacity of the Boltline 3™ production line. This represented a great challenge as the Boltline™/Carbo™ hollow block moulds had already become a highlight on the market after the Big 5 trade fair in Dubai in 2011. All Boltline™ Systems have been successfully launched on the market and will be further supported by ongoing investment in 2013. The high demand has enabled Kobra Formen GmbH to increase its manpower with



TECHNOLOGY MATTERS

NEW! Boltline 3™

Modular system
for maximum cost
effectiveness

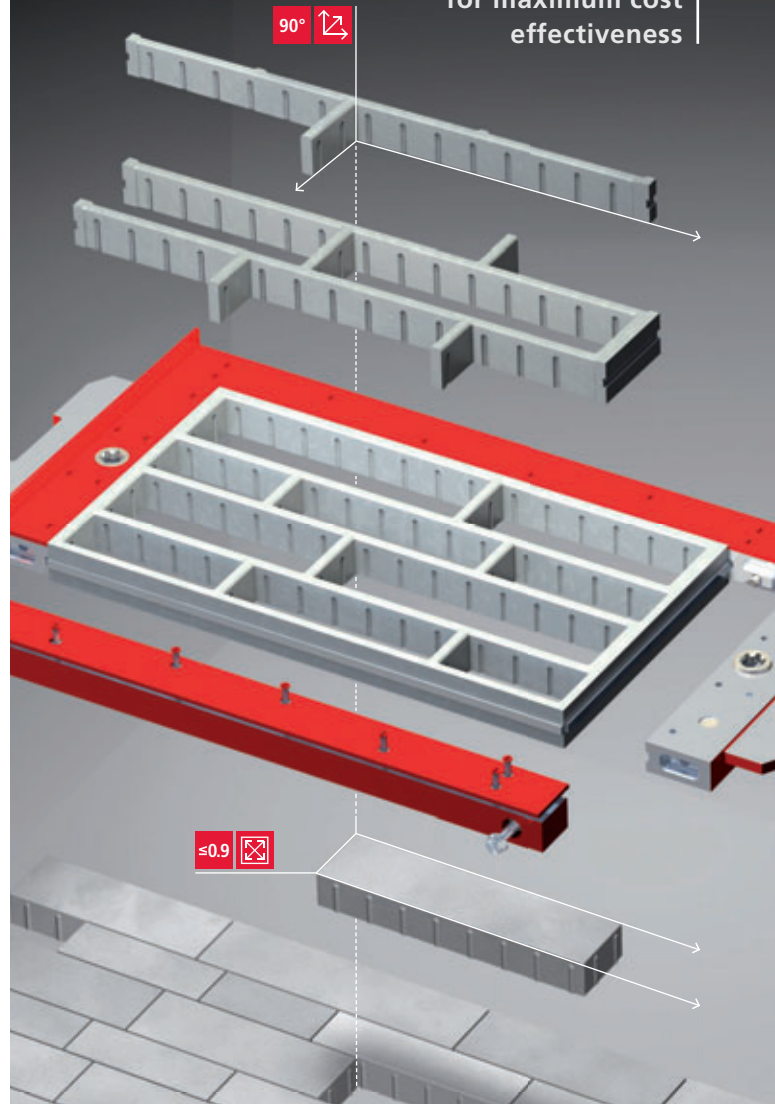

Completely straight and perfectly square.

Diagonal variance at 68 HRC standard ≤ 0.9 mm on products up to 1,250 mm in length.

For impeccable products that set the standard in your market.

LEARN MORE! BAUMA 2013: HALL B1 / BOOTH 111

KOBRA. We build the mould around your stone.
Detailed information can be obtained from our sales team.



*Integral solutions of
high technology and precision.*



VIBROCOMPRESSING PRESSES FOR MAKING SMALL CONCRETE PRODUCTS

Full automatic plants, comprising batching, handling and packaging system.

Wide range of stationary block machines, working both with wooden or steel pallets of different sizes, aiming to satisfy the requirements of each and every project.

Special secondary processes: Splitting, ageing of paving stone blocks, calibration of blocks...



**Bauma
2013** 15.-21.4.2013
booth B1.201

www.poyatos.com

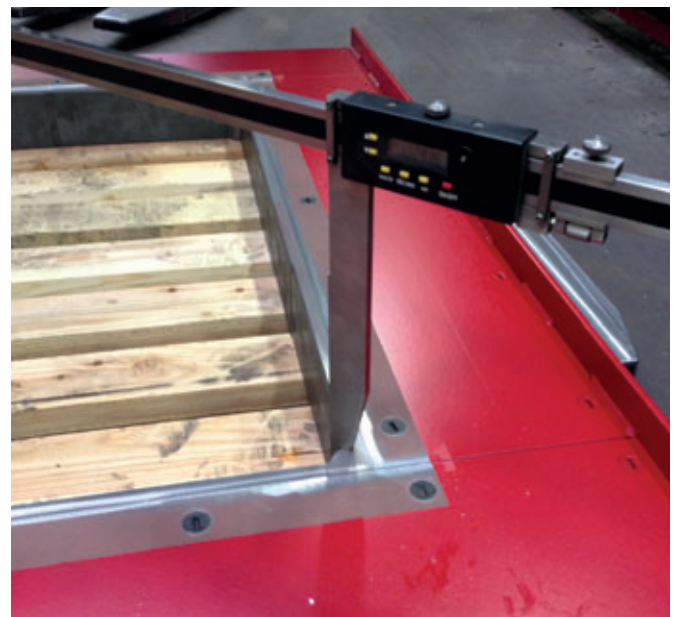

*Testing diagonal deviation during final inspection at Kobra
Formen GmbH*

additional skilled employees in 2012 and maintain the apprenticeship training of the next generation of young talented workers. This all means that Kobra will also continue to be a reliable partner in the concrete goods industry in the future as well.

Interconnections with the latest technology – modular design

The perfection attained with this Boltline 3™ technology has also been achieved through the accompanying connections possible with other modular components from the complete catalogue of Kobra technologies. These generate further positive effects that facilitate manufacturing concrete products of the highest quality. The Boltline 3™ mould can be combined with other Kobra features: Flexshoe™, Hotshoe™ and/or Headguide™.

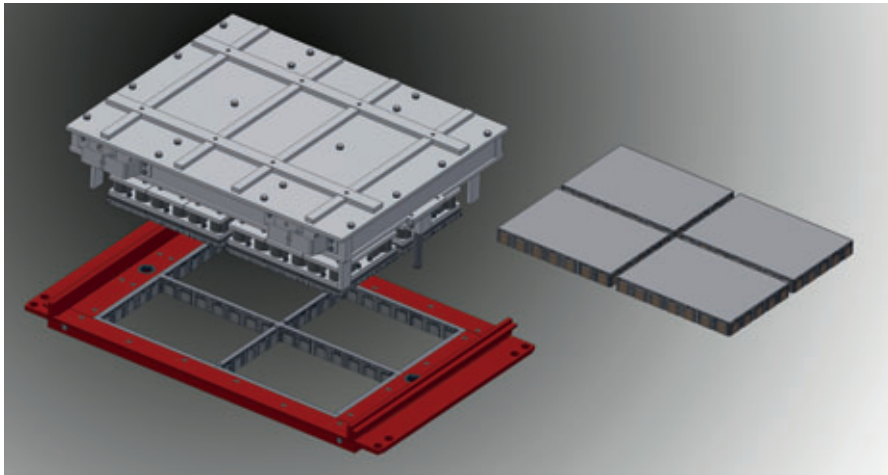

Mould version with Boltline 3™, Optimill Carbo 68+™, Flexshoe™, Hotshoe™ and Headguide™ technologies

Headguide™ technology will be introduced as a new feature at bauma 2013. Headguide™ provides special protection for sensitive mini-fibres in large-format pressure plates. It is not unusual for customers to confirm that service life has been doubled. In addition, this new feature ensures that the entire mould assembly can be inserted absolutely accurately and centrally into the machine. It guides the lower part of the mould precisely during vibration without the pressure plate ever touching the mould's wall.

Flexshoe™ technology has become well-known for better facing concrete compaction with large-size products and is recommended for nominal lengths greater than 400 mm.

Hotshoe™ technology has proved its worth with high quality concrete products since the last bauma in 2010 and has experienced relentless market growth. It is now also available in combination with the Boltline 3™ technology.

It is not uncommon for Kobra customers to order their moulds for large-format paving stone and slab systems – and put them successfully to use - complete with quality parameters including Boltline 3™, Optimill Carbo 68+™, Flexshoe™, Hotshoe™ and Headguide™.

Customers' benefits and effects

Kobra Formen GmbH will strive to advance its technological developments and innovations still further for the greater benefit of its customers. We make it possible for our customers to manufacture superior products by introducing new standards in industry. These high standards are also reflected in

the slogan "Technology – the decisive factor", with which Kobra Formen GmbH will present its new developments at the bauma 2013 trade show in Munich.

FURTHER INFORMATION



KOBRA FORMEN GMBH
Plohnbachstrasse 1
08485 Lengsfeld, Germany
T +49 37606 3020, F +49 37606 30222
info@kobragroup.com
www.kobragroup.com



GODELMANN GmbH & Co. KG
Industriestrasse 1
92269 Fensterbach, Germany
T +49 9438 9404-0, F +49 9438 9404-70
info@godelmann.de
www.godelmann.de



H. Klostermann GmbH & Co. KG - Betonwerke
Am Wasserturm 20
48653 Coesfeld, Germany
T + 49 25 41 7490, F + 49 25 41 74949
info@klostermann-beton.de
www.klostermann-beton.de



Den Anfang macht ein guter Stein
Rinn Beton- und Naturstein GmbH & Co. KG
Rodheimer Strasse 83
35452 Heuchelheim, Germany
T +49 641 60090, F +49 641 6009111
info@rinn.net
www.rinn.net

THE TECHNICALLY SUPERIOR BOARD

- lightweight
- cost-effective
- vibration strength
- bending resistant
- abrasion resistant
- long lasting
- equipment-friendly

for high quality production

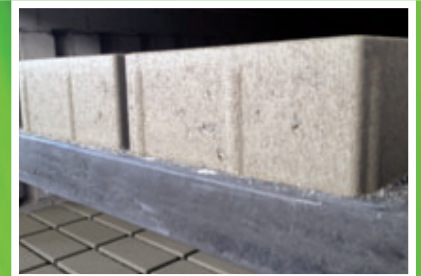

bauma 2013

You find us on bauma 2013
15. – 21. April, Munich
Hall B1, Booth 124

info@tecboard.com · www.tecboard.com